

All-Rack™

6U 600MM (W) X 450MM (D)

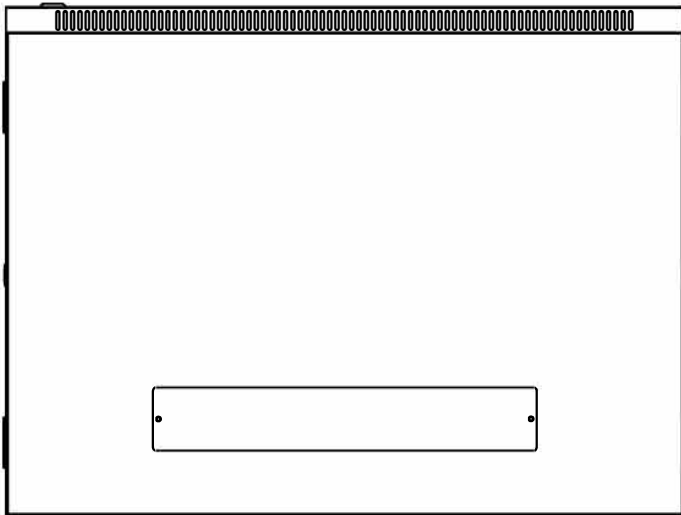

Allrack wall mounted racks and cabinets are designed to be your perfect solution to all of your rack mountable equipment. Available in 4 depths, 300mm, 450mm, 550mm, and 600mm and ideal for small network installations where floor space doesn't allow for a floor standing Server Cabinet. This product is perfect for a single person installation with easy fixing holes. All ALL-RACK wall cabinets have removable and lockable side panels for easy access and security. All cabinets are available in assembled form.

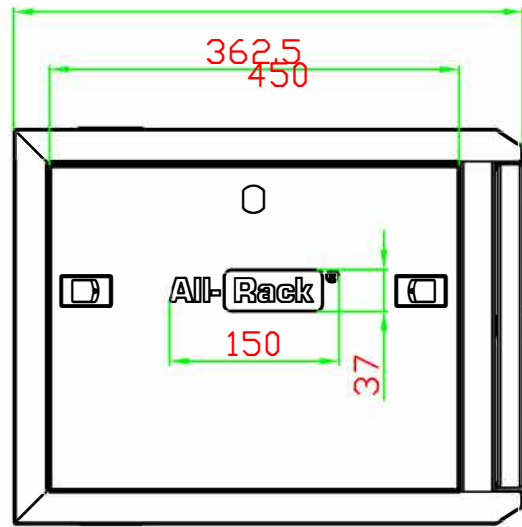
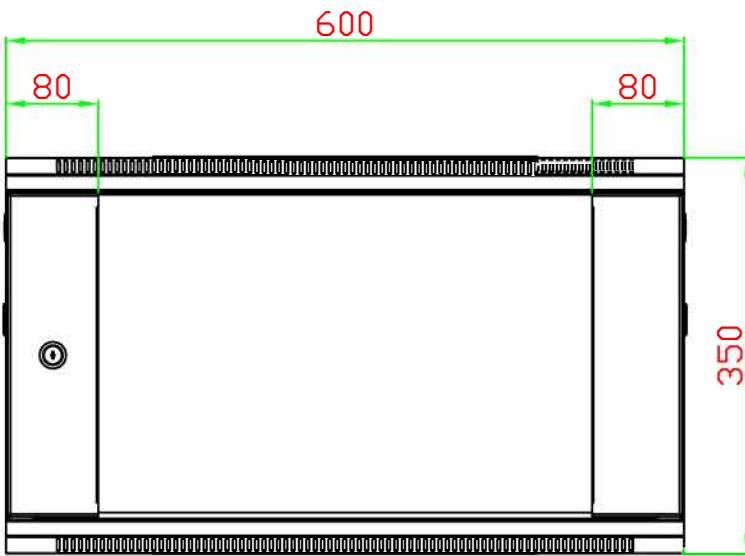

Specification

Partcode: CAB6WB450BLK

Colour: Black RAL9005

Loading capacity: 40kg

Useable Depth: 315mm

Doors: 180 Degrees opening angle & can be mounted on left or right hand side with simple spring latch.

Security: Lockable Doors and side Panels

Ventilation: Optional Fans can be fitted if required

Cable entry: As standard the cabinets are supplied with blank panels however these can be changed into a brush strip panel as an optional extra

Installation: The cabinets can be mounted to the wall by using the fixing holes on the back on the cabinet

Uprights: Front and rear mounting rails are fully adjustable

