

# UltraHorn™ CC 5-24

ULTIMATE NOISE-REJECTING DIRECTIONAL HORN ANTENNA WITH CARRIER CLASS PERFORMANCE

The UltraHorn™ CC 5-24 is a horn antenna with high gain, high directivity, and symmetrical radiation pattern. Symmetrical beam with equal horizontal and vertical beam widths, combined with zero side lobes, offers impeccable performance in terms of interference rejection. No need to spend extra money for radomes, shrouds, or any other additional shielding.

UltraHorn™ CC 5-24 Antenna is suitable for point-to-point links in high noise areas. Thanks to the unique radiation characteristics, UltraHorn™ CC 5-24 delivers excellent performance as narrow beam sector antenna, offering versatile tool for precise network planning. UltraHorn™ CC 5-24 is dual polarization antenna system (H+V) equipped with two N-female connectors.



## TECHNICAL DATA

Antenna Connection	2x N Female Bulkhead Connector
Antenna Type	Horn
Materials	UV Resistant ABS Plastic, Polycarbonate, Polypropylene, Aluminium, Stainless Steel
Environmental	IP55
Pole Mounting Diameter	30-80 mm
Temperature	-30°C to +55°C (-22°F to +131°F)
Wind Survival	160 km/hour
Wind Loading	210 N at 160 km/hour
Mechanical Adjustment	± 25° Elevation, ± 25° Azimuth
Weight	8.7 Kg / 19.1 lbs – single unit 9.7 Kg / 21.4 lbs – single unit incl. package
Single Unit	Retail Box: 57.0 x 57.0 x 66.0 cm

## PERFORMANCE

Frequency Range	5180 - 6400 MHz
Gain	24 dBi
Azimuth/Elevation BW -3 dB	H 11° / V 11°
Azimuth/Elevation BW -6 dB	H 16° / V 15°
Polarization	Dual Linear H + V
Front-to-Back Ratio	40 dB
VSWR Max 5180-5850 MHz	1.6
VSWR Max 5850-6400 MHz	1.8

## PRODUCT DIMENSIONS

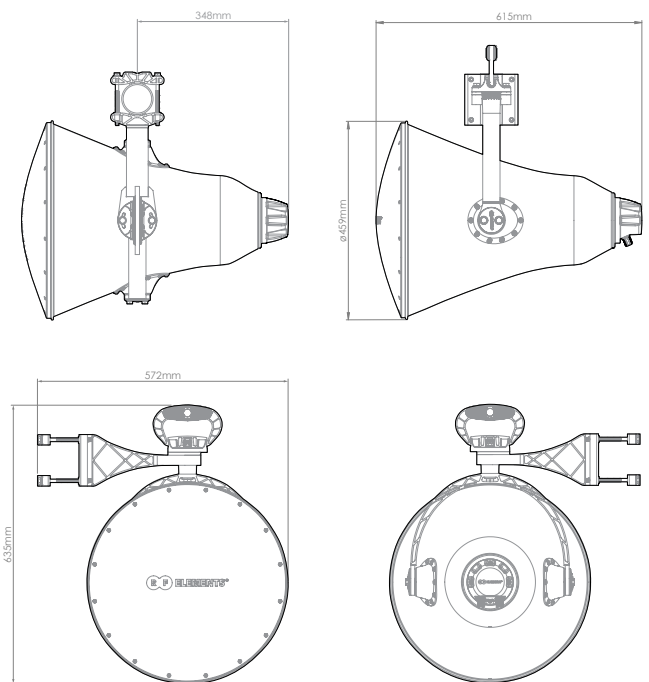

## AZIMUTH PATTERN

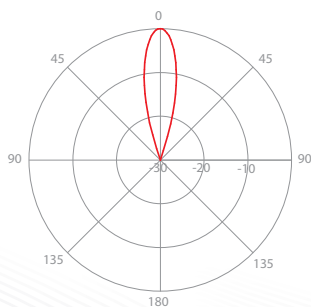

V/H - Port Pattern Azimuth 5.5 GHz

## ELEVATION PATTERN

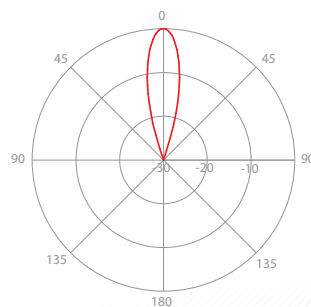

V/H - Port Pattern Elevation 5.5 GHz

## GAIN

